

Flow switch, mechanical

For continuous fluid measurement without power supply

Model FSM-BSV

WIKA data sheet FL 60.02

Applications

- Machine building
- Chemical industry
- Cooling and lubrication systems
- Recirculation

Special features

- High switching accuracy and functional safety
- Switch point repeatability of $\pm 5\%$
- Large switching range, low switch hysteresis
- Viscosity-compensated models available
- Continuous switch point setting by the user



Left: Indication without switch version
Right: Indication with switch version

Description

The model FSM-BSV flow switch is designed for flow indication and monitoring of liquids in cooling circuits and systems of welding machinery, laser and pipeline systems, dosing systems, pumps, compressors, hydraulic systems, high-pressure plants and many more.

Based on the piston working principle, a float (piston), with its integrated magnet, is moved by the medium in the direction of the flow within a cylindrical slotted nozzle or measuring tube. When the switch contact position is reached, the float stops.

When the flow rate increases, the piston moves further, at most until it reaches the end stop position, preventing the float from being driven beyond the switching range.

The flow switch enables a microswitch contact to be mounted outside of the flow circuit. The switch contact is cast into a continuously adjustable switch case and thus is protected from external influences.

The model FSM-BSV flow switch is a compact flow meter used for operational controls that prevent system failures in the absence of liquid supply.

Specifications

Basic information	
Contact version	<ul style="list-style-type: none"> ■ Without ■ 1 x SPDT (single pole double throw) ■ 2 x SPDT (single pole double throw)
Design	<ul style="list-style-type: none"> ■ Without indication ■ With indication
Dial	
Scale colour	Black
Material	Aluminium
Nominal size (NS)	<ul style="list-style-type: none"> ■ DN 8 ■ DN 10 ■ DN 15 ■ DN 20 ■ DN 25 ■ DN 32 ■ DN 40 ■ DN 50 ■ DN 65 ■ DN 80
Case	GF nylon for LVD version (Low Voltage Directive)
Pointer	
Material	<ul style="list-style-type: none"> ■ Plastic, black ■ Aluminium, black
Weight	2 ... 3 kg [4.4 ... 6.6 lb]

Sensor element	
Type of measuring element	Piston with antagonist spring
Sensor housing	
Material	<ul style="list-style-type: none"> ■ Brass, nickel-plated, for nominal size ≤ DN 40 (ASTM: C38500 / DIN: 2.0401) ■ Stainless steel 316L (ASTM: A276 / DIN: 1.4404)
Wetted parts	<ul style="list-style-type: none"> ■ Barium ferrite magnet (BaFe-magnet) ■ Stainless steel 304 with PTFE-coated spring

Accuracy specifications/repeatability	
Indication accuracy	± 5 % of full scale value
Non-linearity	± 5 % of full scale value
Repeatability	± 5 % of full scale value

Setting range		
Nenngröße (NG)	Einstellbereich, Ab- oder zunehmender Durchfluss ^{1) 3) 4)} in LPM (Liter pro Minute)	FL (Durchflusslimit) ²⁾ in LPM (Liter pro Minute)
DN 8	0.3 ... 3	6
	0.5 ... 5	10
	1 ... 8	16
	2 ... 12	24

Setting range		
Nenngröße (NG)	Einstellbereich, Ab- oder zunehmender Durchfluss ^{1) 3) 4)} in LPM (Liter pro Minute)	FL (Durchflusslimit) ²⁾ in LPM (Liter pro Minute)
DN 10	0.3 ... 3	6
	0.5 ... 5	10
	1 ... 8	16
	2 ... 12	24
DN 15	0.3 ... 3	6
	0.5 ... 5	10
	1 ... 8	16
	2 ... 12	24
	5 ... 25	50
	7 ... 35	70
DN 20	12 ... 40	80
	0.3 ... 3	6
	0.5 ... 5	10
	1 ... 8	16
	2 ... 12	24
	5 ... 25	50
	7 ... 35	70
	10 ... 40	80
DN 25	25 ... 60	120
	40 ... 85	170
	0.3 ... 3	6
	0.5 ... 5	10
	2 ... 12	24
	5 ... 25	50
	7 ... 35	70
	12 ... 40	80
DN 32	20 ... 60	120
	40 ... 110	220
	25 ... 60	120
	30 ... 90	180
DN 40	40 ... 110	220
	50 ... 150	300
	60 ... 230	460
DN 50	50 ... 150	300
	75 ... 175	350
	90 ... 220	440
DN 65	100 ... 200	400
	180 ... 330	660
DN 80	180 ... 330	660
	330 ... 500	1,000

1) In the absence of customer specification, the switch point will be preset on decreasing flow to the middle of the range [i.e. 50 % of span + minimum range value].

2) Maximum flow that the sensor element can withstand without suffering permanent damage. The instrument might have to be calibrated afterwards.

3) The set point and reset point of the switch should not exceed the upper and lower range limits.

4) The above flow ranges are recorded with water as the medium (density $\rho = 1000 \text{ kg/m}^3$ at pressure, $P = 1 \text{ atm}$, temperature $T = 25 \text{ }^\circ\text{C}$ [77 °F]).

Process connection	
Standard	<ul style="list-style-type: none"> ■ ANSI/ASME B1.20.1 ■ DIN ISO 228
Thread size	
ANSI/ASME B1.20.1	<ul style="list-style-type: none"> ■ ¼ NPT, female thread ■ ⅜ NPT, female thread ■ ½ NPT, female thread ■ ¾ NPT, female thread ■ 1 NPT, female thread ■ 1 ¼ NPT, female thread ■ 1 ½ NPT, female thread ■ 2 NPT, female thread ■ 2 ½ NPT, female thread
DIN ISO 228	<ul style="list-style-type: none"> ■ ¼ BSP, female thread ■ ⅜ BSP, female thread ■ ½ BSP, female thread ■ ¾ BSP, female thread ■ 1 BSP, female thread ■ 1 ¼ BSP, female thread ■ 1 ½ BSP, female thread ■ 2 BSP, female thread ■ 2 ½ BSP, female thread ■ 3 BSP, female thread
Sealing	EPDM
Type of mounting	<ul style="list-style-type: none"> ■ Horizontal in-line pipe mounting ■ Vertical in-line pipe mounting (flow direction bottom to top)

Output signal	
Switching function	<ul style="list-style-type: none"> ■ 1 x SPDT (single pole double throw) ■ 2 x SPDT (single pole double throw) for version without dial only
Setting range	→ See table "Setting range"
Hysteresis	≤ 45 % of full scale value
Minimum load	→ See table „Electrical rating (1 x SPDT)“

Electrical connection	
Connection type	<ul style="list-style-type: none"> ■ DIN (DIN EN 175 301-803-A) ■ M12 connector (male, back mount, straight)
Pin assignment	The pin assignment is given on the product label on the instrument. Connection terminals and the ground terminal are appropriately marked.
Ingress protection per IEC 60529	IP65

Pin assignment

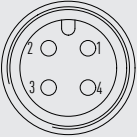
Circular connector M12 x 1 (4-pin)		
	1	NO = Normally open
	2	COM = Common contact
	3	NC = Normally closed
	4	-

Angular connector DIN 175301-803-A (4-pin)		
	1	NO = Normally open
	2	COM = Common contact
	3	NC = Normally closed
	4	-

Operating conditions	
Place of use	Indoor applications
Altitude	Up to 2,000 m
Medium temperature range	-20 ... 110° C [-4 ... 230 °F] → Liquid media with the property of changing the volume during solidification can damage the measuring system (e.g. water if it falls below the freezing point).
Ambient temperature range	-20 ... +80 °C [-4 ... +176 °F]
Storage temperature range	-20 ... +80 °C [-4 ... +176 °F]
Permissible media	<ul style="list-style-type: none"> ■ Water ■ Oil (viscosity of 30 ... 600 cSt)
Mounting position	<ul style="list-style-type: none"> ■ Horizontal ■ Vertical
Permissible pollution degree	2
Overvoltage category	II
Weight	Approx. 2 ... 3 kg [4.4 ... 6.6 lb] (depending on model)

Electrical rating									
AC current				DC current					
Resistive load		Inductive load		Resistive load			Inductive load		
125 V	250 V	125 V	250 V	30 V	125 V	250 V	30 V	125 V	250 V
5 A	3 A	3 A	2 A	4 A	0.4 A	0.2 A	3 A	0.4 A	0.2 A

Approvals

Logo	Description	Region
	EU declaration of conformity	European Union
	Low Voltage Directive	
	RoHS directive	

→ For approvals and certificates, see website

Dimensions in mm [in]

Model FSM-BSV with indication NS 8 ... 25

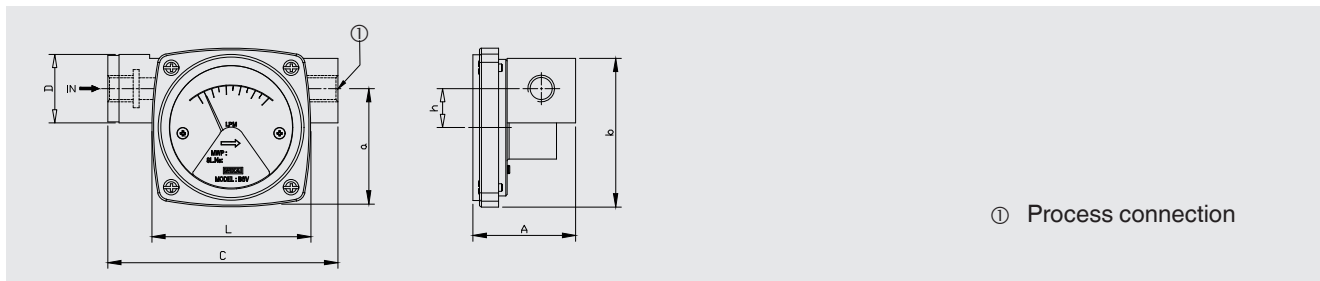

① Process connection

NS	Process connection NPT/BSP	C	D	h	A	b	L	a
DN 8	1/4"	122 [4.80]	36 [1.417]	20.5 [0.807]	54 [2.126]	78 [3.071]	83.5 [3.287]	62.3 [2.453]
DN 10	3/8"							
DN 15	1/2"							
DN 20	3/4"							
DN 25	1"	159 [6.26]	40 [1.575]	22.5 [0.886]	58 [2.283]	84 [3.307]	-	-

General tolerance: ± 1 mm [0.039 in]

Model FSM-BSV with indication and switch NS 8 ... 25

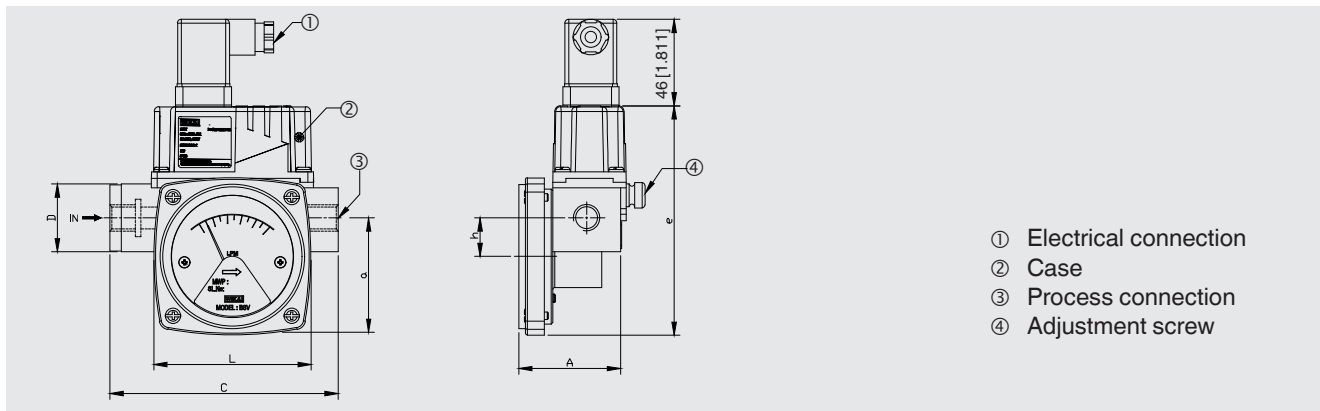

① Electrical connection
 ② Case
 ③ Process connection
 ④ Adjustment screw

NS	Process connection NPT/BSP	C	D	h	A	e	L	a
DN 8	1/4"	122 [4.80]	36 [1.417]	20.5 [0.807]	54 [2.126]	122 [4.80]	83.5 [3.287]	62.3 [2.453]
DN 10	3/8"							
DN 15	1/2"							
DN 20	3/4"							
DN 25	1"	159 [6.26]	40 [1.575]	22.5 [0.886]	58 [2.283]	124 [4.882]	-	-

General tolerance: ± 1 mm [0.039 in]

Model FSM-BSV SPDT switch NS 8 ... 25

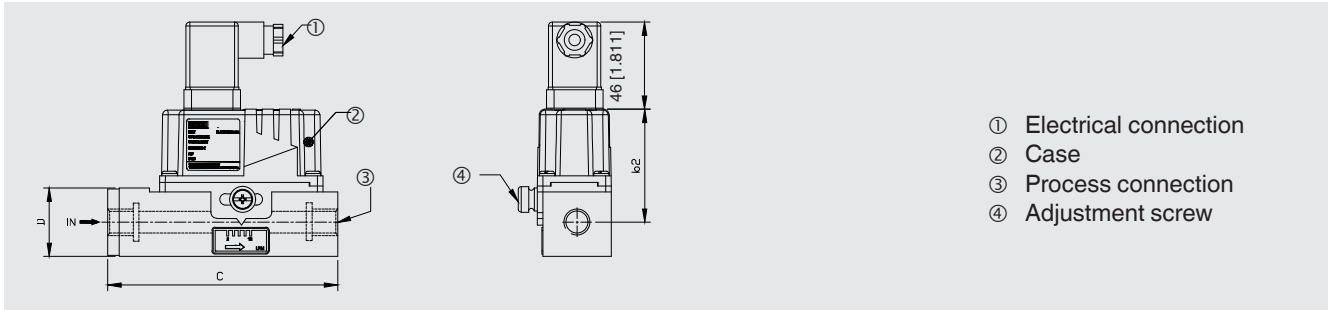

- ① Electrical connection
- ② Case
- ③ Process connection
- ④ Adjustment screw

NS	Process connection NPT/BSP	C	D	b2
DN 8	1/4"	122 [4.80]	36 [1.417]	59.5 [2.343]
DN 10	3/8"			
DN 15	1/2"			
DN 20	3/4"			
DN 25	1"	159 [6, 26]	40 [1.575]	

General tolerance: ± 1 mm [0.039 in]

Model FSM-BSV DPDT switch NS 8 ... 25

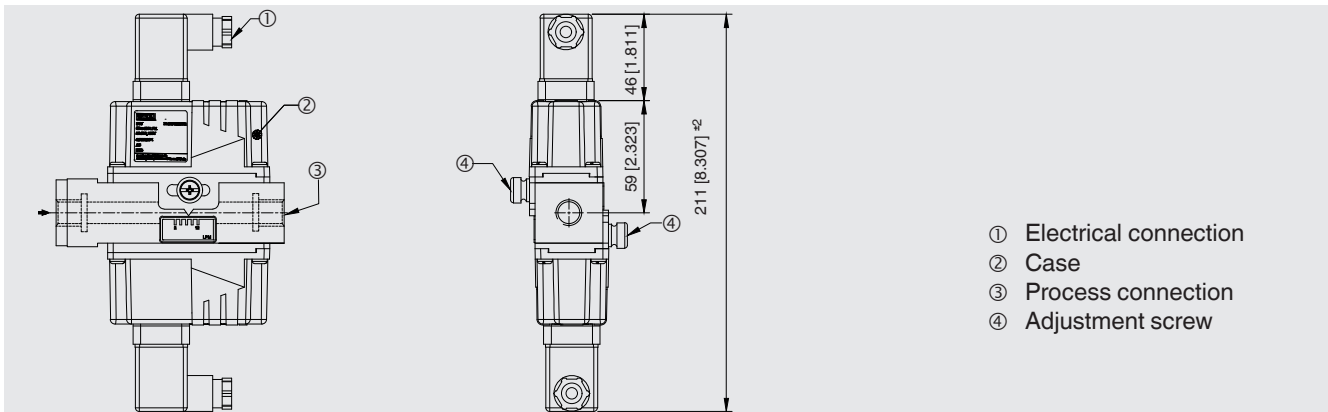

- ① Electrical connection
- ② Case
- ③ Process connection
- ④ Adjustment screw

NS	Process connection NPT/BSP	C	D	b2
DN 8	1/4"	122 [4.80]	36 [1.417]	59.5 [2.343]
DN 10	3/8"			
DN 15	1/2"			
DN 20	3/4"			
DN 25	1"	159 [6.26]	40 [1.575]	

General tolerance: ± 1 mm [0.039 in]

Model FSM-BSV SPDT switch NS 32 ... 80

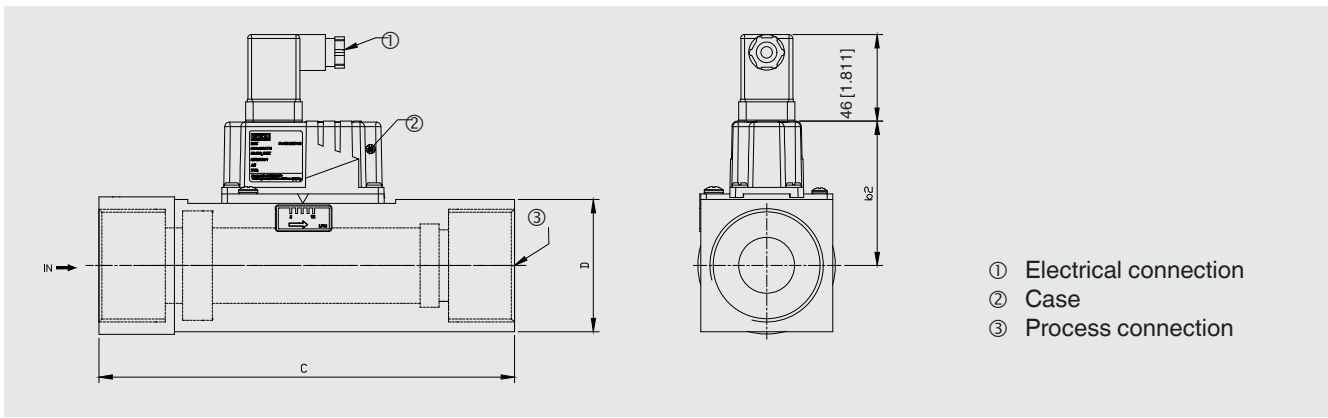

- ① Electrical connection
- ② Case
- ③ Process connection

NS	Process connection		C	D	b2
	NPT	BSP			
DN 32	1 ¼"	1 ¼"	128 [5.039]	70 [2.756]	76 [2.992]
DN 40	1 ½"	1 ½"			
DN 50	2"	2"	220 [8.661]	75 [2.953]	76.5 [3.012]
DN 65	2 ½"	2 ½"		90 [3.543]	76 [2.992]
DN 80	-	3"		114 [4.488]	91 [3.583]

General tolerance: ± 1 mm [0.039 in]

Model FSM-BSV DPDT switch NS 32 ... 80

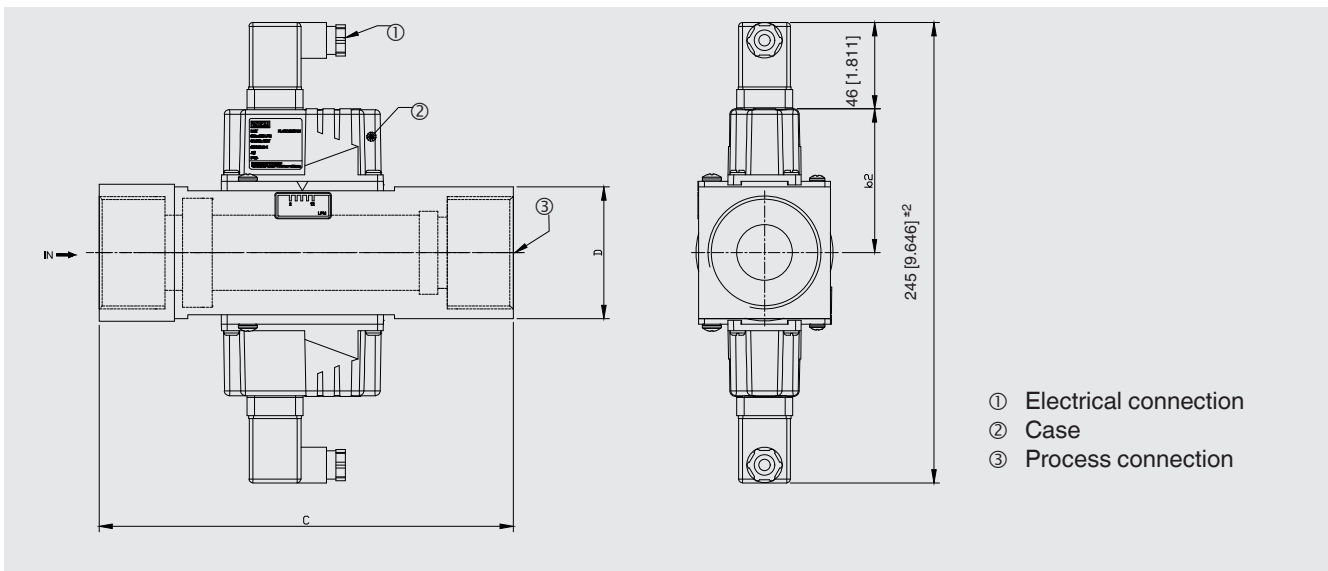

- ① Electrical connection
- ② Case
- ③ Process connection

NS	Process connection		C	D	b2
	NPT	BSP			
DN 32	1 ¼"	1 ¼"	128 [5.039]	70 [2.756]	76 [2.992]
DN 40	1 ½"	1 ½"			
DN 50	2"	2"	220 [8.661]	75 [2.953]	76.5 [3.012]
DN 65	2 ½"	2 ½"		90 [3.543]	76 [2.992]
DN 80	-	3"		114 [4.488]	91 [3.583]

General tolerance: ± 1 mm [0.039 in]

Process connection

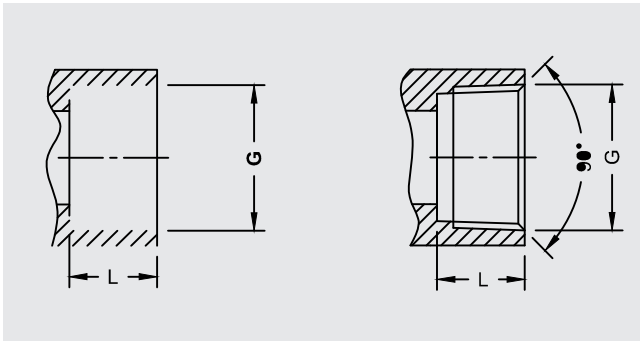

NS	G		L
	NPT	BSP	
DN 8	1/4"	1/4"	18 [0.71]
DN 10	3/8"	3/8"	
DN 15	1/2"	1/2"	16 [0.63]
DN 20	3/4"	3/4"	
DN 25	1"	1"	20
DN 32	1 1/4"	1 1/4"	22
DN 40	1 1/2"	1 1/2"	
DN 50	2"	2"	35 [1.38]
DN 65	2 1/2"	2 1/2"	
DN 80	-	3"	40 [1.57]

General tolerance: $\pm 1 \text{ mm}$ [0.039 in]

© 06/2021 WIKA Alexander Wiegand SE & Co. KG, all rights reserved.
 The specifications given in this document represent the state of engineering at the time of publishing.
 We reserve the right to make modifications to the specifications and materials.
 In case of a different interpretation of the translated and the English data sheet, the English wording shall prevail.

